

With Alidade and Tape

Graphical and plane table survey of archaeological earthworks



Introduction

This paper is designed to assist anyone who wishes to undertake a large-scale (1:1000 or 1:500), detailed survey of an archaeological earthwork site. It aims to show why traditional graphical and plane table techniques (Figs 1 and 21) are of value in recording and understanding such earthwork sites. It describes the techniques and the equipment required, and the products of such survey. The purpose of analytical surveys of archaeological earthworks is to make a systematic record of them in such a way that they can be viewed comprehensively. This enables their interpretation in terms of:

- form, including shape, size and orientation
- relative (and sometimes absolute) chronology, often by demonstrating relationships between features
- location and topographical setting
- function or purpose

Surveys also provide a statement on the condition of earthworks and other historic features, aid their management and conservation, and inform archaeological decisions on them (regarding, for example, scheduling, preservation or excavation).



Figure 2 'Total station' EDM: electronic survey instruments supply control to a high degree or accuracy, but are not absolutely necessary for archaeological survey. Indeed, it is worth remembering that before the 1970s all survey was done without benefit of electronic instrumentation, to levels of accuracy far higher than those needed for archaeological earthwork survey.

The value of graphical and plane table techniques

In an era of rapidly advancing technology, a technical paper on traditional survey techniques might be thought to require some justification. Many archaeologists routinely use advanced technological surveying equipment such as Electromagnetic Distance Measurement (EDM) (Fig 2) and differential Global Positioning System by Satellite (GPS), which has immense advantages in ease of use, in speed of operation and in the creation of digital data sets (Ainsworth and Thomason forthcoming). Nevertheless, traditional techniques still have advantages in the detailed analytical survey of archaeological earthworks at large scale (usually 1:1000 or 1:500), where understanding and interpretation are as important as accurate recording. These advantages can be summarised as follows:

- **Technique** – electronic equipment enforces a particular approach to survey, and one that is not necessarily conducive to the intelligent recording and understanding of subtle archaeological earthworks. The use of traditional equipment, on the other hand, enables a more flexible approach, and the treatment of archaeological features as complete entities, rather than as series of lines to be chased. The use of traditional equipment entails a close observation of the ground surface in a way that the use of electronic equipment does not.
- **Cost** – hi-tech equipment is costly and beyond the reach of most amateur archaeological groups or individuals, professional archaeologists in other parts of the world, and even many small professional organisations in this country.
- **Reliability** – simpler equipment is less prone to breakdown and is generally more easily repaired. Though most hi-tech surveying equipment is robust and reliable, it is not immune to breakdown, which can be particularly trying, especially in remote areas. In these circumstances the ability to undertake non-instrumental survey using basic trigonometry is a great advantage.
- **Error and omission** – drawing in the field in the traditional way eliminates the unwitting development of error or the omission of detail; if something is wrong or missing it is immediately obvious and can be corrected on the spot. Many electronic systems store data that is only plotted later, off-site, and errors are not identified until it is too late. Newer systems (such as 'pen computers') with field graphics capability are less prone to this problem,

but do not overcome the other objections raised here.

- Depiction – fully digital drawings have not been capable of showing the subtlety of depiction obtainable from traditional hand drawings. The drawing of hachures has been a particular stumbling block for electronic drafting packages and, though there are signs that this might have been overcome by the latest generation of applications, the problem cannot yet be regarded as solved.
- Speed – hi-tech surveying kit, particularly GPS, is a powerful tool that can record vast amounts of data very rapidly. There is no doubt that in rapid survey ('Level 1') and landscape survey ('Level 2') situations it is unbeatable (Ainsworth and Thomason forthcoming). However, in large-scale survey ('Level 3'), detail can be captured at least as fast by traditional as by electronic means. Furthermore, undertaking both control and detail survey by traditional methods avoids the need to process electronic data, which can be time-consuming. (For a definition and description of Levels of Survey see Bowden 1999, 73–80 and Appendix 1; RCHME 1999.)

No one should confuse the ability to use electronic instruments with the ability to see and understand archaeological remains; the second is not necessarily a corollary of the first.

Field surveys undertaken using a combination of electronic and traditional techniques offer:

- a descriptive and analytical account of the site
- an accurate and analytical plan
- relative heights and profiles, where necessary
- an accurate location
- a platform on which to base further interpretation
- a permanent record of the site at a given time

Interpretation and recording

The purpose of archaeological earthwork survey is twofold. First, it is intended to produce an accurate scale plan of the site – to record it. Secondly, and at least as important, is to gain understanding of the site – to interpret it.

This twofold aim requires a particular type of survey. If all that was necessary were an 'objective' cast of the site's surface

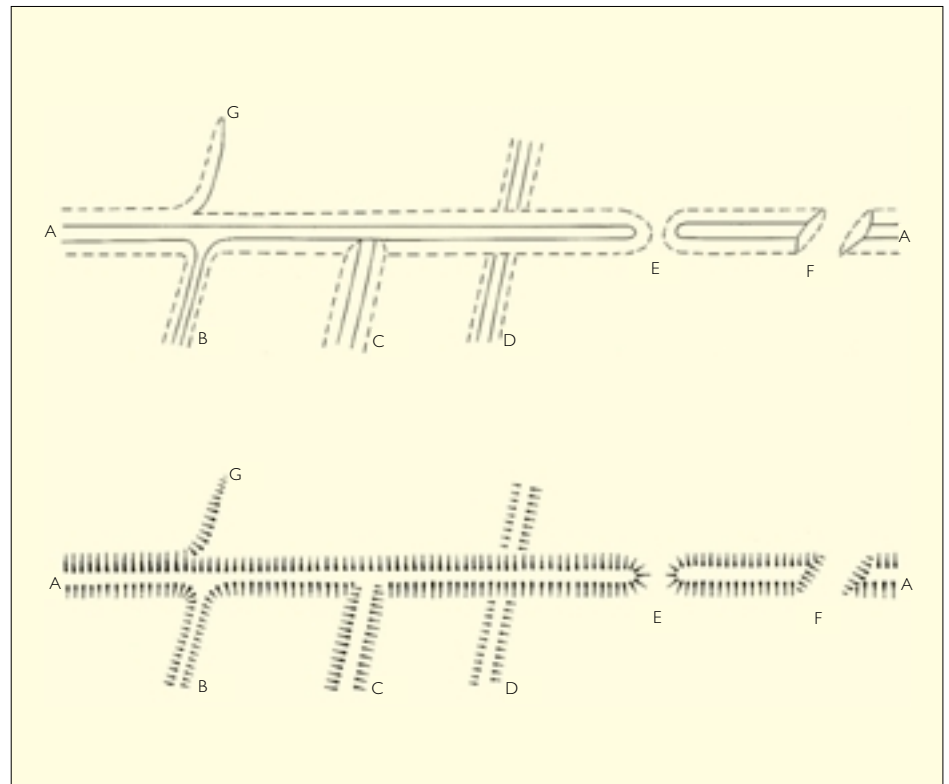

Figure 3 The depiction of chronological relationships in field (top) and archive (bottom) drawings. Bank A–A: • has no certain relationship with B and is probably contemporary; • is overlain by, and is therefore earlier than, C; • overlies, and is therefore later than, D; • has a gap, probably original, at E; • has been cut by a later breach at F. The scarp at G fades into the natural topography

morphology, then a contour survey would offer the best solution. Contour survey has value in setting the archaeological features within their natural topographical context, and is now best achieved through the use of GPS (Ainsworth and Thomason forthcoming), but is of very little value in understanding the archaeological earthworks themselves. Instead, conventional hachured survey has been found the best way to portray earthworks and their interrelationships. This is because arrays of hachures can:

- indicate the all-important relative chronology of features (Fig 3)
- distinguish between natural and artificial slopes;
- give a consistent portrayal of earthworks as they turn across or along natural slopes.

Contours can do none of these things. If electronic instrumentation is not available, contouring is best avoided altogether – it is tedious, time-consuming and the results do not repay the effort (Taylor 1974, 48–52). Hachured survey can be characterised as 'subjective', but also as thoughtful and skilful; contouring, which is thought of as 'objective', is mechanical and routine. Hachured survey therefore requires the measurement and depiction primarily, but not exclusively, of the tops and bottoms of slopes. A description of two methods for doing this forms the main body of this paper. The depth of interpretation that can be

achieved through earthwork survey, especially in combination with other non-intrusive techniques, is considerable. This is discussed in Taylor 1974 (chapter 4) and Bowden 1999 (chapter 5), and recent case studies can be found in, for instance, Bowden *et al* 1989, Pattison 1998, Pattison *et al* 1999, Frodsham, *et al* 1999, Ellis 2000 (chapter 5) and Everson 2001.

Reconnaissance, and Control and Detail survey

Any large-scale archaeological earthwork survey involves three main field stages: reconnaissance, control survey and detail survey. **Reconnaissance** is the initial field visit (or visits) during which decisions will be made about survey strategy and site logistics. There might also be an element of archaeological assessment. The survey strategy questions to be addressed at this stage concern: the purpose of the survey; the area to be covered; survey techniques and equipment, and personnel, to be employed; the scale of the survey; the level of accuracy required; and the likely time scale. The site logistics questions will encompass: site ownership and access; health-and-safety issues; legal constraints; and other potential problems (eg public access, grazing animals). All of these issues are discussed in Bowden 1999 (44–7). The significant point is that thorough and careful reconnaissance saves time later.

Choice of scale is one of the most important decisions to be taken during reconnaissance. The scale should reflect the complexity of the earthworks; all other factors, such as the size of any eventual publication drawing, are very much secondary considerations. This paper is concerned primarily with survey at scales of 1:1000 or 1:500. The former has been the mainstay of Royal Commission and, latterly in England, English Heritage fieldwork for some years because it combines the ability to show all significant earthwork features with sensible coverage. The larger scale should only be contemplated where masonry detail has to be shown. In such cases it might be possible to survey a 'window' around the masonry part at larger scale and supply the remainder of the site at a smaller scale. The 'window' can then be shown as an inset or as a separate drawing. Doubling the scale of a survey can mean quadrupling the number of points to be measured, and therefore the time taken. Experience shows that it is possible, with a sharp pencil and care in drafting, to 'push' the scale to show the smallest significant earthwork at 1:1000. At these scales the basic unit of measurement is the decimetre (or 'dec') = 10cm = 0.1m. It should be possible for anyone with good eyesight and a sharp pencil to plot to an accuracy of 2 decs.

The first stage of the survey itself is the establishment of **control**, a rigid and accurate framework, consisting of a series of fixed points linked to each other by angular and linear measurements, on which the detail will hang. At the large scales we are considering here, 1:1000 and 1:500, no existing map base is available, so control will have to be supplied by the surveyors in the field. In most cases control is best established electronically (because electronic survey is accurate, whatever distances are involved, whereas errors increase with distance in taping and plane tabling). Electronic control survey will not be described here, as such descriptions are available elsewhere (eg Bowden 1999, 47, 52–8 and references therein; Ainsworth and Thomason forthcoming). On all but the largest sites, however, the control survey can be done by the manual methods described below. As suggested above, this can be a useful shortcut, avoiding the need to process electronic data – the survey can run through as a single task.

The control will physically consist of ground markers put in by the surveyor and existing 'hard' features in the landscape. The former might include pegs, golf tees, chalk or paint marks, the latter buildings, fences, telegraph poles, drain covers, but also any masonry elements of the archaeological features. These are all surveyed in and plotted on the control diagram, which then becomes the

field document on which the 'soft' archaeological detail is drawn.

All earthworks, where identification of the tops and bottoms of slope is a matter for subjective judgement, are described as 'soft' detail.

All field and archive drawings should be on plastic drawing film (at least 125microns thick) if possible; it is stable and does not shrink, stretch or warp like paper, and therefore maintains the accuracy of the drawing. It is expensive, but not as expensive as the time, effort and equipment required to ensure a high degree of accuracy in the field. To plot the expensively achieved accuracy of a control plot on such an unstable medium as paper is a false economy. Electronically supplied control should be plotted in waterproof ink. Where this is unavailable or where the control is hand drawn, to avoid accidental erasure of control during detail survey the points should be pricked through the plastic or marked on the reverse side of the film.

When designing a control scheme, the aim should be to place control points close to, but not on, archaeological features. In this way long offsets are avoided, but survey construction lines do not obscure the archaeological detail. Points should be placed less than 60m apart so that they are within two 30m tapes of each other, or so that plane table rays do not normally have to exceed 30m.

The final stage, **detail survey**, is the essence of analytical earthwork survey; using the measuring process to examine the earthworks – their forms, patterns and relationships – to unravel the story of the site. The following parts of this paper describe two methods of achieving this.

Graphical survey

Graphical survey, or tape-and-offset survey (sometimes still referred to as 'chaining'), is a simple method of supplying earthwork measurements and requires only the most basic equipment. Though this method works best with two people – one measuring and one plotting – it can be done by one person.

Equipment

A minimum of three plastic-coated fibron **tape measures**, in a combination of 20m or 30m and 50m lengths, will be suitable for most jobs. A **spike** attached to the zero end of each tape is invaluable but, failing that, **survey arrows** can be used to anchor tapes. They can also be used to keep them straight

in windy conditions, if loose surface stones or other handy weights are not available. At least two **ranging rods** will be needed for marking base lines. If large numbers are needed, however, **bamboo canes** with fluorescent tape attached make adequate markers. A **plumb bob** might be necessary for taping on sloping ground. An **optical square** consists of two pentagonal prisms mounted one above the other in a plastic or metal housing, enabling the accurate observation of 90° offsets and 180° alignments. It is extremely useful for laying out offsets longer than about 5m, where laying out 'by eye' is insufficiently accurate (Figs 4–6). It is the only 'instrument' generally used in tape-and-offset survey, though a **prismatic compass** is useful, and **pocket sextants** and **pantometers** (see below) can be used. An alternative to the optical square is a **crosshead**, a tube mounted on a ranging rod, with vertical viewing slits at 90° (or 45°) angles to one another.



Figure 4 The optical square in use, raising a long offset from a tape line.

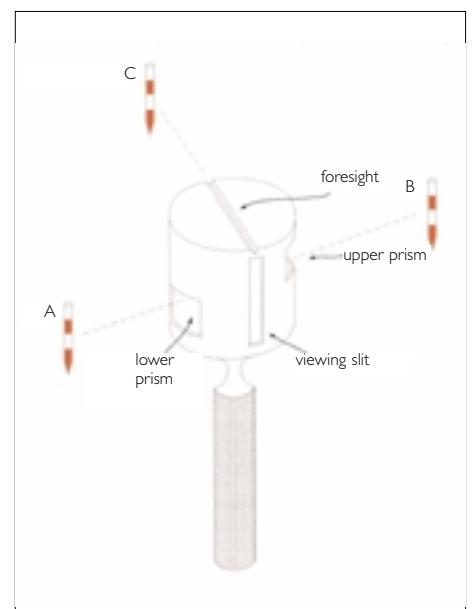

Figure 5 The optical square: diagram.

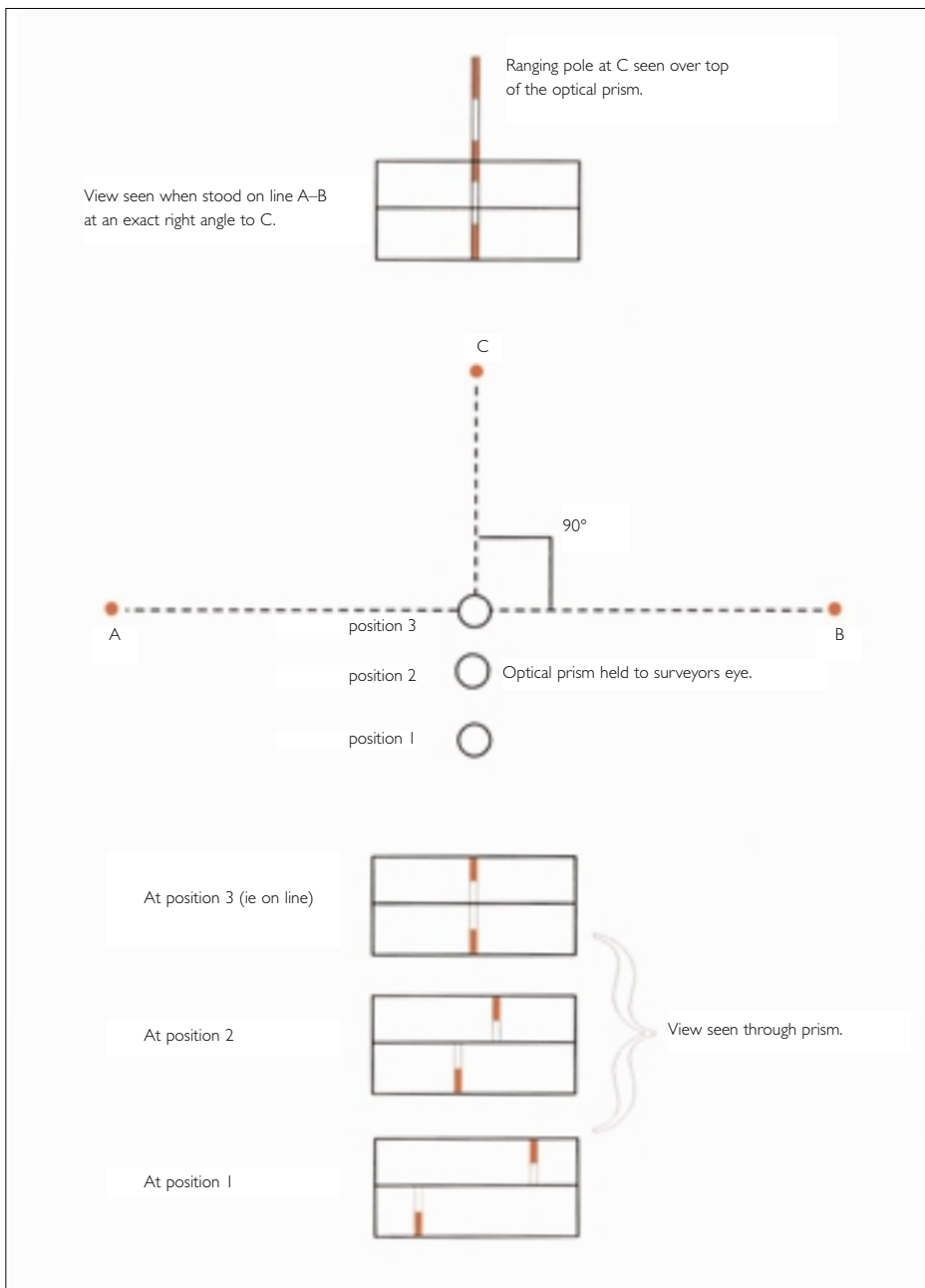

Figure 6 Using the optical square: schematic diagram.

A field drawing board, measuring about 580mm × 660mm and light enough to be carried on a shoulder strap, is invaluable. Purpose-made boards can be obtained for mounting on a lightweight tripod, providing a portable table that can be very useful. Alternatively, boards can be made cheaply from marine 3-ply covered with Papyroboard. The control diagram, on 125micron **drawing film** (or, in the case of a small site where the control is to be supplied manually, a blank sheet of film), should be attached to the drawing board with **masking tape**. (Fix the centres of the long sides first, then the centres of the short sides, and only then the corners; this ensures a flat lie. Finish off by running tape all around the edge of the sheet to create a dirt and shower proof seal.) A **notebook** is always useful for field noting, though this can

also be done on the plan or on a voice recorder. If you do not have a drawing board and are not going to draw in the field, a notebook becomes essential. In this case a **surveyor's chaining book** is required, set out and used as in Fig 7.

The final essential is a **drawing kit**. This should contain a **pencil**, preferably a fixed gauge (0.3–0.5mm) clutch type with a hard lead (3H–7H) and an appropriate **sharpener** (a piece of **emery board** or similar for getting a really fine pencil point is a good idea). A **scale rule** appropriate for the survey in hand is essential, ideally 15cm long (the 'toblerone' type are best avoided – they often lead to errors in plotting as they are invariably picked up with the wrong scale showing). A **setsquare** is necessary for laying off right angles – a 60°/30° type about

15cm long is ideal, larger ones being awkward to use in the field and difficult to pocket. A pencil-type **rubber** will be found necessary for precise erasures. A longer **straightedge** is useful on some sites for drawing long base lines.

Care of such basic equipment is very straightforward. It should all be kept clean and dry. Wet tapes should be left in a loose coil to dry before rewinding, and should be rewound between two fingers of the hand holding the case, to decrease the likelihood of kinking and to remove any mud or dirt. A wet optical square, like any optical instrument, should be left out at normal room temperature to dry gradually before being returned to its case.

Methods

When dealing with a site where control has not already been established electronically, this would be the first process. It is achieved by running a base line across the site and from this supplying any walls, fences or hedges defining the boundaries of the survey, and any other 'hard' detail, before turning to the archaeological 'soft' detail. If subsidiary control lines are necessary they must be carefully measured and checked to ensure accuracy. This checking can be done by basic triangulation – raising a series of triangles from measured points along the base line (see Taylor 1974, 46). The simplest method might be, if a 50m tape is available, to construct a 30m, 40m, 50m triangle (see below), for instance. Measurements from subsidiary lines to check the positions of 'hard' detail features will also confirm the accuracy of the survey.

If it is necessary to lay out a base line longer than the longest available tape, this is done by 'ranging the line'. The stations at each end (A, B) are marked by vertical ranging rods. One surveyor stands about 1m behind the ranging rod at station A and sights the one at B, directing a colleague to move right or left to place a third, intermediate, rod accurately and vertically on line at C. If more than one intermediate rod is required, the first is put in furthest from the surveyor, so as not to obscure the sighting of the other(s). A surveyor working alone can find the line between two ranging rods precisely with an optical square. (For methods of surveying around or dealing with obstacles on a base line see Coles 1972, 78–84.)

A distinct advantage of graphical survey is that it can easily be done by an individual working alone. Should the control also be graphical, an individual can do the whole survey job from start to finish with cheap, lightweight equipment. However, there are

advantages to teamwork. There are practical considerations, involving both health-and-safety issues and the management of tapes, ranging rods and other equipment over a large site. At least as important is the consideration that two pairs of eyes are useful in the observation of subtle, and sometimes fugitive, earthworks, and that archaeological interpretation benefits from discussion.

The survey method consists of the creation of a series of lines, by taping between any of the fixed control points. These can be marked by ranging rods or canes. The aim is to reduce the site to small, clearly defined portions within which attention to detail can be focussed. Features are then plotted by setting out right angles, or offsets, from the tape lines using, if necessary, an optical square (Figs 4–6) or crosshead and measuring along these offset lines to tops and bottoms of slopes, and so on. Other features that might be observed and plotted include breaks of slope, vegetation changes, parchmarks, or scatters of stone.

It is often desirable to drop a perpendicular (right angle) to the base line from a point of interest rather than to raise one from the base line in the hope of hitting the required point. This can also be done with the optical square; the point to be measured (C) is marked with a ranging rod and the surveyor walks along the base line (A–B) with the optical square, keeping the ranging rod at the end of the base line in the centre of the foresight until the image of the ranging rod at (C) coincides with it.

If an optical square or crosshead is not available the tapes themselves can be used to raise a perpendicular from the base line, or to drop a perpendicular to it. The simplest methods are described here. In a triangle with sides 3, 4 and 5 units long (or multiples thereof – a small triangle will not give accurate results if the sides are produced over a long distance), the angle between the two shorter sides is a right angle. Such a triangle can easily be constructed on the base line with one or two other tapes. A quick method of dropping a perpendicular to the base line is 'swinging the tape'; the zero end of the tape is spiked at the point to be measured and the tape is swung back and forth over the base line. The shortest measurement observed gives the perpendicular. Care has to be taken to avoid snagging the swung tape on tussocks or stones. (For further methods of measuring perpendiculars with tapes see Coles 1972, 73–5).

Offsets are taken where appropriate. Placing them to avoid waste of time and effort, and yet to miss no significant detail, is a matter of experience (Fig 7). Lines other than

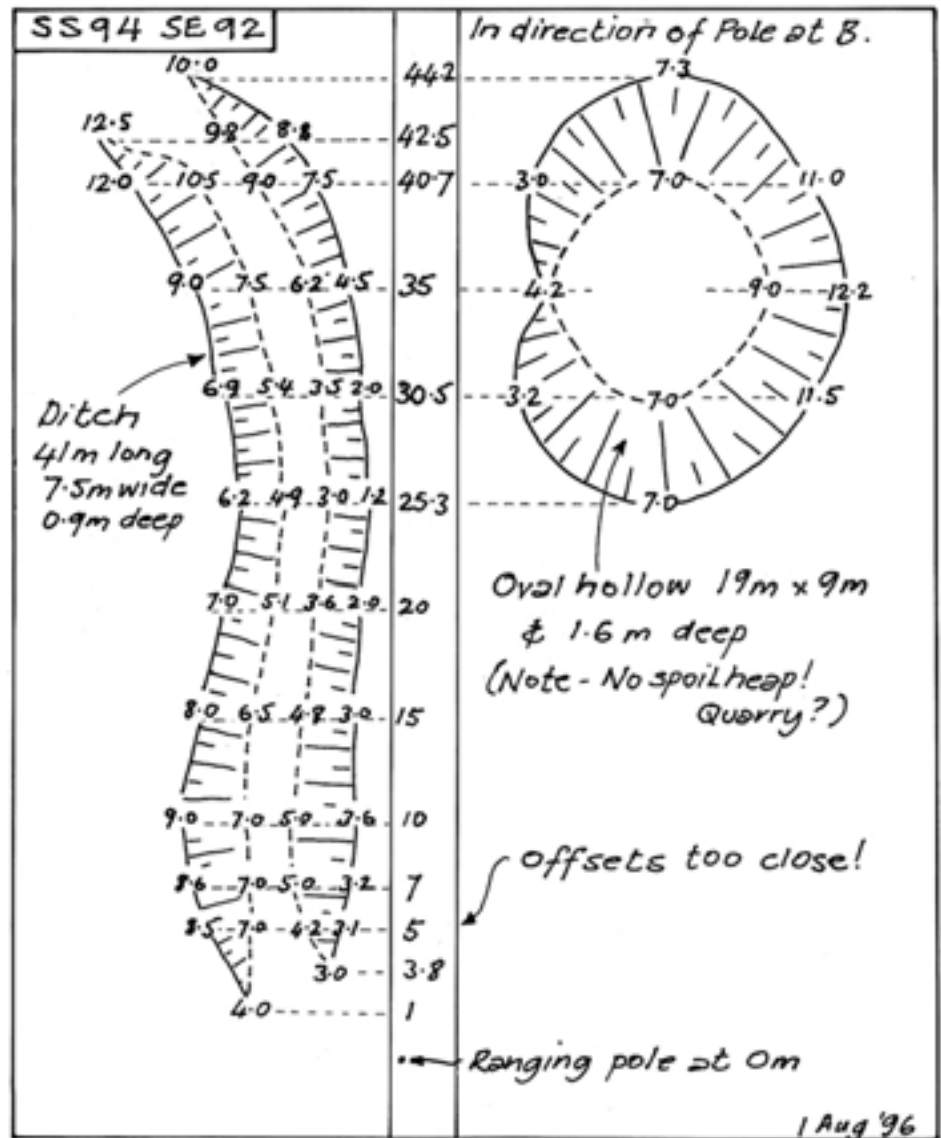

Figure 7 Tape-and-offset survey logged in a surveyor's chaining book. The central column represents the tape line A–B, with offsets to detail on either side.

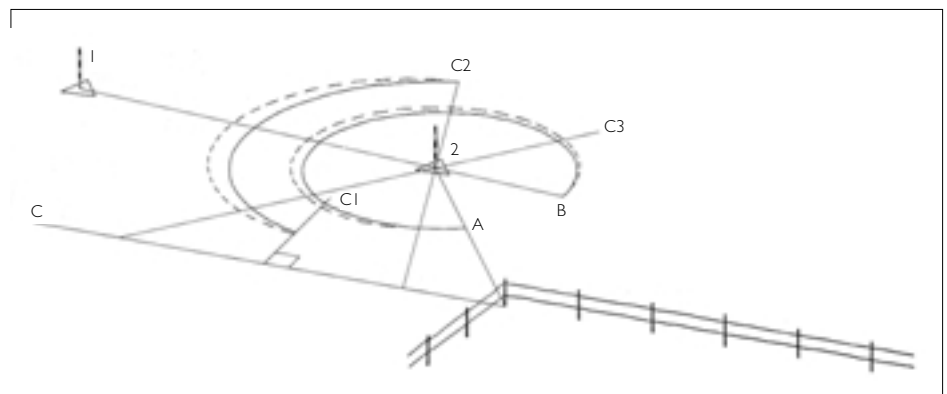

Figure 8 Graphical survey: schematic diagram. From control point 2: A is a measurement 'in direction of' the fence corner post; B is a measurement 'pulling back' control point 1; C is a line established by 'extending the straight' of the fence for offsetting and 'shots' through point 2 (C1, C2, C3).

offsets can be used; measuring from the base line 'in direction of' another marked point, 'pulling back' a point or 'extending a straight' (Figure 8). These measurements can then be re-created on the plot with scale rule and setsquare. Tops and bottoms of slopes, and other measured features can be

joined to produce an accurate portrayal of the archaeological detail. As long as the control is accurate, the resulting plan will be accurate.

The quality of the survey depends ultimately on the care with which the earthworks and

other features are observed, measured and portrayed. Circular features can be plotted by supplying a central point from an offset and then taking a series of subsidiary measurements around the circumference from that point. A linear feature is best surveyed from a base line running close alongside, from which a series of offsets charts its course. Chronological relationships, where observed, must be accurately portrayed (Fig 3, C, D). Care must be taken to portray the ends of a slope, or any breaks in its length, accurately. An original terminal in a bank or ditch might appear as a rounded 'bullnose', while a later break might give rise to a 'chiselled' end (Fig 3, E, F). Alternatively, a slope might simply fade into the natural topography, portrayed as a 'point' where the top and bottom lines come together (Fig 3, G).

On field survey drawings the convention is that tops of slopes are shown by continuous lines, free-drawn, and bottoms of slopes by pecked (dashed) lines (Fig 3, top diagram). Ruled lines are reserved for hard detail. A variety of chain-and-dot lines can be used to indicate breaks of slope, vegetation marks and so on.

The actual identification of tops and bottoms of slopes can be difficult, even where earthworks are clearly defined (Taylor 1974, 40). Supplying a slight scarp on a natural slope is a real test, and no two people will necessarily agree about exactly where tops, bottoms or end points lie. In these circumstances taking the measurements in a consistent manner is more important than worrying about the value of each individual measurement. With very gentle slopes it is a good rule of thumb to err on the side of measuring them 'short', because otherwise they might appear too dominant on the final plan.

More difficult still is the observation of the all-important chronological relationships – determining which elements are earlier, and which represent later developments, alterations or complete re-workings of the site. Practice and experience bring more confident recognition of such relationships but they must always be sought and, when found, depicted and noted accordingly. Success in achieving this, and progressing to more detailed interpretation of the 'total history' of the site in its landscape setting, is the true end and ultimate justification for earthwork survey. It also confounds the unwarranted accusation that earthwork survey can only deal with the final phase of any site.

Before fieldwork is completed magnetic north must be determined. This can be done by taking a bearing along the longest convenient base line with a prismatic compass (beware of proximity to a metal ranging rod). The reading should be taken in both directions as a check – the difference should be 180°, of course. Magnetic north can then be calculated and marked on the plan, with the *date* – magnetic north varies with time.

There are some basic surveying rules that must be followed to avoid errors and ensure accuracy.

- Always 'tie out' tape lines between control points (ie measure the full distance) and check by scaling off on the plot before surveying any detail. Deal with any errors immediately to avoid cumulative errors later.
- Remember that 'slope' distance on the ground is longer than the horizontal or 'plan' distance that you wish to plot. When taping on sloping or uneven ground keep the tape measure in the horizontal plane. If necessary, measure a long line down a slope in a series of 'steps', holding the tape level and plumbing down to the ground at convenient points.
- Lay base lines as close to features as possible, so that you can use short offsets, ensuring accuracy and saving time.
- The accuracy of plotting must be equivalent to the accuracy of measurement. For example, where it is necessary to use an optical square or geometric method to lay out the offset, it will also be necessary for the plotter to use a setsquare to plot it (Fig 9); there is

no point in taking the trouble to measure the angle accurately if it is then plotted 'by eye'.

- Avoid laying tapes across features at oblique angles, as this can give rise to odd results on plan.
- Plot survey detail in the field if at all possible. If it is not possible, compile clear, unambiguous field notes.
- Keep all drawing light, neat and clear.
- Check all completed work before leaving the site.

Plane table survey

The plane table is one of the oldest surveying instruments and, though no longer in general use, is still useful for archaeological surveying and is an invaluable tool for teaching the principles of survey.

Equipment

The plane table kit consists of: a **tripod**; a **drawing board** or table that can be mounted on the tripod, and rotated and clamped in the horizontal plane; an **alidade** (or sight rule), which can be a simple straightedge with sighting vanes or a telescopic type such as a self-reducer, or one with an EDM attached; a **spirit level** (usually a 'pond' bubble) to ensure that the table is level; and a **plumbing fork and bob** to ensure that the ground position represented on the table is vertically above the actual ground position. A telescopic alidade requires the use of a **surveying staff**. In addition to these, all the equipment mentioned above for graphical survey (with the exception of the portable drawing board and lightweight tripod) could be used.

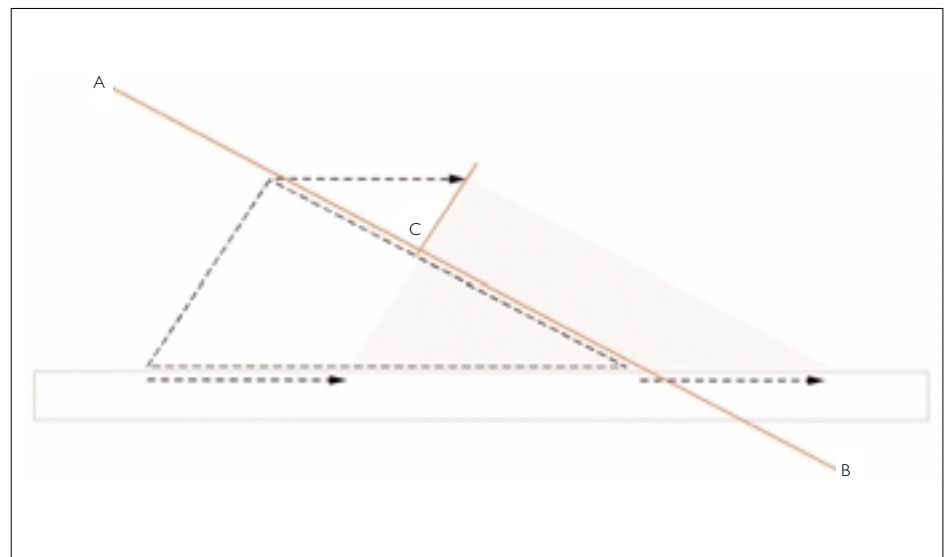

Figure 9 A useful method of plotting a right angle is: first, lay the setsquare on the plan so that the longer side adjacent to the right angle lies along the base line (A–B); next, lay the scale rule (or another straightedge) along the hypotenuse of the setsquare; then, holding the scale rule steady, slide the setsquare along it until the shortest side of the setsquare is against the point from which the right angle is to be raised (C), and draw the right angle.

The basic alidade is an instrument that measures angles only – a line can be drawn on the plan in precisely the same direction as the object sited on. Telescopic alidades measure distance as well as angle; the self-reducer is an optical instrument that automatically converts slope distance to horizontal distance, and enables heights to be calculated; an alidade-mounted EDM works in the same way as a more conventional EDM, combining electronics with traditional technology. With the self-reducing alidade distances can be read to an accuracy of about 0.1m at 50m (acceptable for large-scale survey). Some basic alidades and most telescopic ones have parallel motions for increased flexibility of use.

Plane tables must be detached from tripods before moving them, to avoid putting undue strain on the joint. An optical alidade should always be transported in its box, and, if it gets damp, must be dried at normal room temperature at the end of the day before being put away. All equipment should be carefully wiped clean before being put away at the end of the day.

Method

There are several ways of using a plane table; the following describes just one method – radiation – using control stations and points previously fixed and plotted, for surveying archaeological detail by angular and distance measurements. Though a plane table can be used for control survey at small scales it is not sufficiently accurate for large-scale control, except on small sites (less than 150m maximum dimension) where the whole area can be surveyed from one set-up (or, at most, two, at either end of a measured base line). An example is given in Fig 10. It is assumed for the purposes of the following description that all control stations and points, and hard detail, have been supplied and are marked on a control plot to be taped to the plane table board. It is especially important in plane tabling to get the plastic film flat on the board and to ensure that the masking tape around the edge is well fixed, to allow for smooth movement of the alidade.

Plane tabling with a basic alidade can be done by an individual though, as in graphical survey, there are benefits to working with a partner. If a telescopic alidade is to be used a partner is essential. One person surveys the features while the other observes through the alidade and plots the detail on the table. Although one (the former generally) takes responsibility for the survey, both have equally valuable roles in its completion – teamwork is essential.

Setting up and confirming the position of the first station

There are three requirements for a plane table set-up: the plane table must be horizontal, correctly positioned over the station, and correctly orientated.

At the first point to be occupied the plane table board is mounted on the tripod, approximately orientated to the site, and the whole is set up, using the plumbing fork and bob, and the pond bubble (Fig 11). It is fixed, level and firm, into the ground so that



Figure 11 Levelling the plane table with a pond bubble.

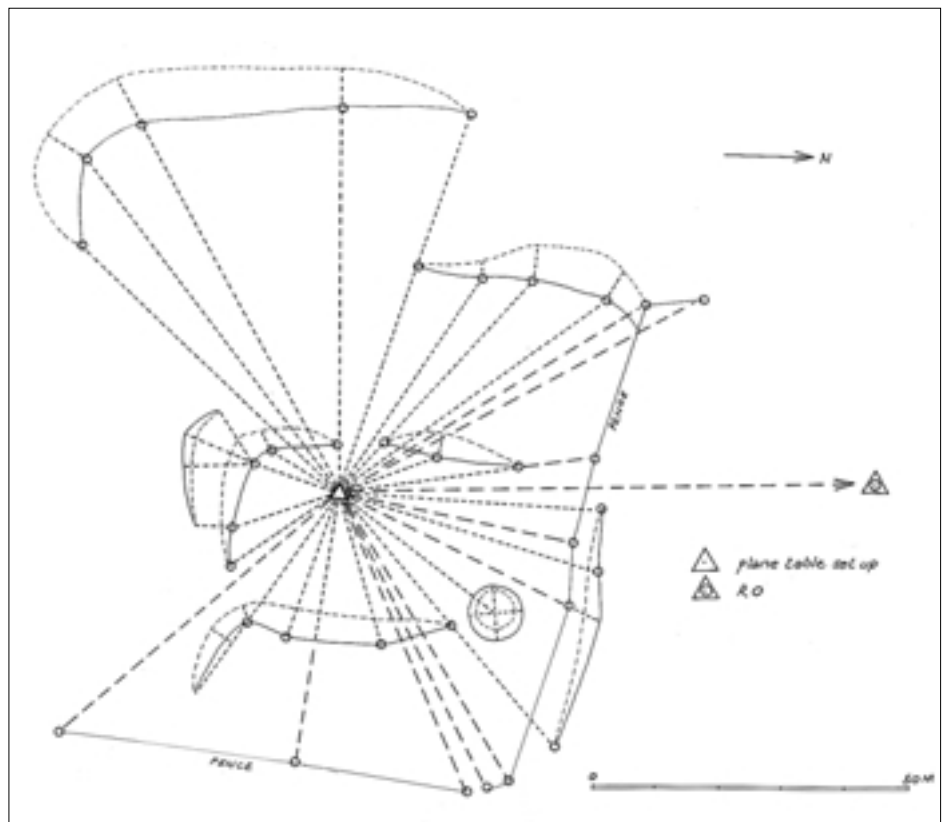

Figure 10 A small site surveyed entirely from a single plane table set-up. The lines of long pecks represent measurements to 'hard' detail (the fence); the short pecks represent measurements to 'soft' detail. Each primary measurement from the table is represented by a small circle. The subsidiary measurements from these points are all taken along the rays, or 'in direction of' or 'pulling back' other previously established points. In one case, an offset has been raised from a tape line extending one of the rays.

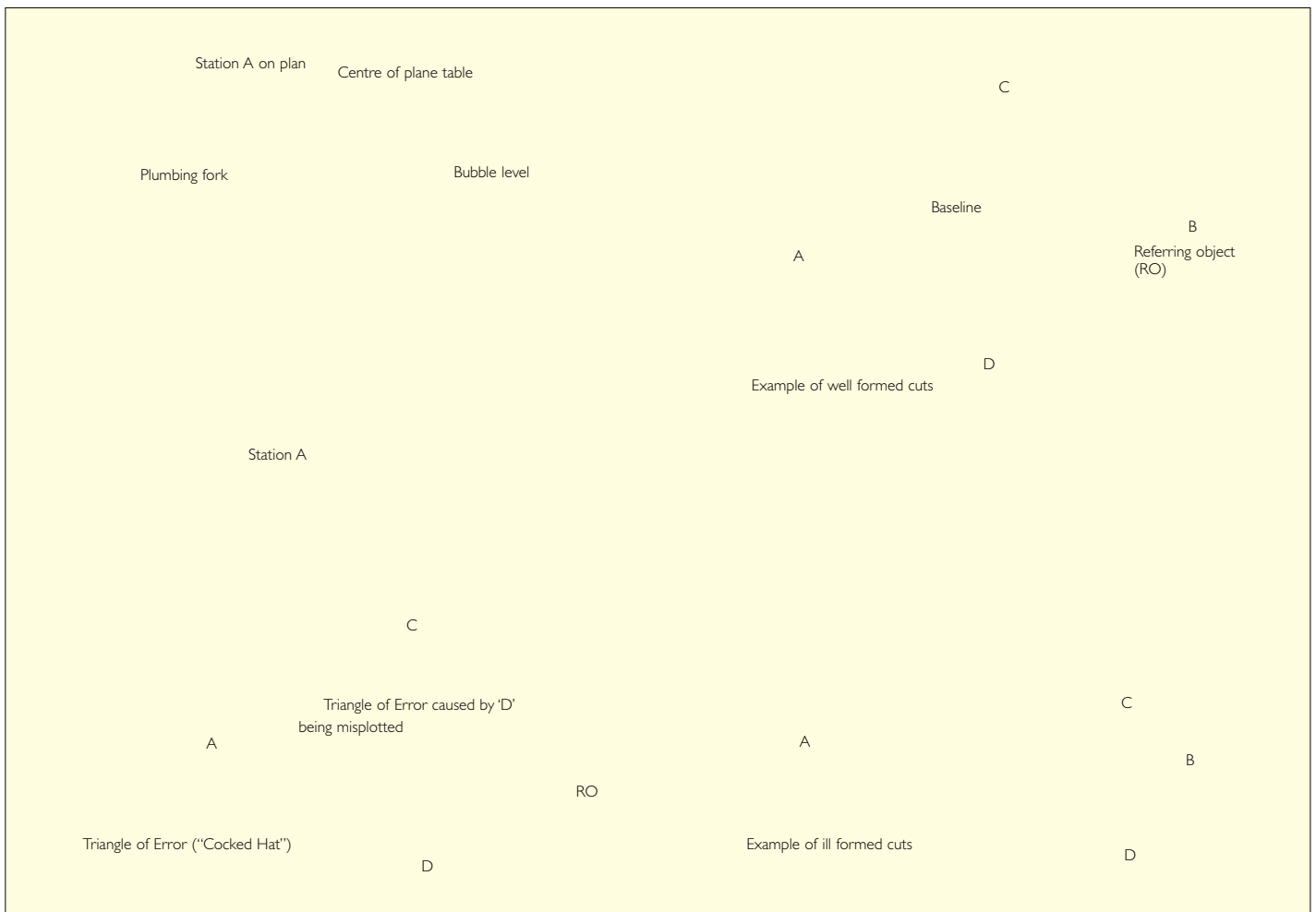

Figure 12 The plane table set-up, RO and checks: schematic diagram.

the clearly identified control point on the film (not the centre of the board) is positioned directly above (ie within about 10cm of) the point on the ground that it represents (Fig 12). Approximately align or orient the board by eye so that the other control points are *roughly* in their correct relative positions. Gently clamp the board in position. From the control point chosen (A) draw a line to another visible control point (B), the Referring Object ('RO') (Fig 12). For accuracy the RO should be as far away as possible, but this will be limited by the length of the alidade blade. (Taking a distant RO ensures that detail is supplied **within the control**. It is wrong to select an RO 20m away and then supply detail at greater distances, as this contradicts a fundamental rule of survey – work from the whole to the part, within the control, not from the control outwards.) No distance measurement to the RO is required, only its orientation.

Place the alidade blade along the line (A–B). (In the case of a telescopic alidade, level the instrument using its horizontal and vertical bubbles, and adjust for parallax.) Sight through the alidade and gently loosen the clamp attaching the board to the tripod. Swing the board round until the alidade

sights are precisely on point B. (Telescopic alidades have rifle sights to assist with orientation but the final adjustment must be made with the vertical stadia hair of the telescope itself.) Ensure that the alidade blade has not moved off the line A–B. Clamp the board tightly in position. It is now oriented, ie the control points on the board and on the ground are in the same relative positions.

It is *essential* to apply a check before proceeding. This is a fundamental rule of survey. Select a third control point (C) and sight onto it with the alidade, keeping the blade on (or, in the case of alidades with parallel motions, to the left of) (A) on the board. The point (C) should be, if possible, between 60° and 120° to the line (A–B), ensuring a good fix with a well formed cut (Fig 12). Draw a light pencil line along the blade through (C); it should cut through (A), confirming its position. Repeat by selecting a fourth control point (D), preferably on the other side of the line (A–B) and at a similar angle. This should give a perfect tri-section on (A), meaning that the three lines of sight (or 'rays') from (B), (C) and (D) meet at a single point (A), proving its absolute accuracy.

This procedure confirms another rule of survey: what happens on the ground must also happen on the plan. If, instead of a perfect tri-section at (A), the three rays form a 'triangle of error' (or 'cocked hat') (Fig 12), the error must be located before proceeding with survey. Go back to the beginning and check everything – it is usually the only way. Potential sources of error are:

- (a) the board might have been moved off its initial orientation
- (b) mis-identification of the initial control station (A) – the set up is over a different point
- (c) mis-identification of (A) on the plan
- (d) mis-identification of (B), (C) or (D) on the ground or on the plan
- (e) one of the control points has been incorrectly plotted (common with manually computed and plotted control, but rare with electronic control).

Once the position is checked and confirmed survey can proceed.

Some plane table kits contain a trough compass for supplying accurate magnetic north to the plan. Remove the alidade and any other metal objects from the board.

Place the trough compass near the edge of the board and release its clamping screw. Wait for the needle to settle, then slowly turn the compass until it points north. Draw a line on the plan along the edge of the compass, mark it with an arrowhead and annotate 'magnetic north' and the date. This operation is done at the first set up only, of course. The trough compass, however, can be used for approximately orientating the board at subsequent stations; the compass is placed against the magnetic north line already established and the board rotated until the needle points to magnetic north, but the orientation must then be checked by observation to other control points.

Preparing to supply survey detail

At this stage it is a good idea to have a close look at the archaeological detail, and for the team to discuss what will be shown and how it will be represented on plan. Deal with one small area at a time. (If the alidade has its own set of scale bars, the correct one should be slid into the parallel bar at this point).

Start by surveying any topographical detail (eg road edges) that has not already been fixed as control. These are easily dealt with and provide a clear framework for the archaeological features, giving shape and form to the survey. This 'hard' detail can also be used to help supply further detail with less effort later on.

Supplying survey detail with a basic alidade

Place a ranging rod or other marker on the first point of detail (E). With the alidade blade on (or to the left of) (A) sight onto the marker and, holding the alidade steady, draw a line along the blade from (A). Measure the distance from the set up (A) to the point of detail (E) with a tape and scale this off on the drawing, marking it with a small dot on the line. If necessary, use a tape to take measurements from the plotted point to supply further detail. These can be measurements along the ray towards/away from the table, or perpendicular to the ray, or in direction of/pulling back another control point or hard detail point. In this way, for instance, a multi-ditched and banked feature can be plotted by an alidade reading to one point, the remainder obtained by taping across the feature at right angles to it, saving further work with the alidade. Increasing experience tells which 'short cuts' maintain accuracy and which do not. Having captured any detail that can be obtained from this point move on to the next and repeat. Join points representing tops and bottoms of slopes, etc, as you go.

Supplying survey detail with a self-reducing alidade

The surveyor holds the staff vertically on the point of detail (E), facing the plane table and not obscuring the staff with the hands (Fig 13). The observer aligns the alidade on

the staff using the rifle sites, ensuring that the blade is to the left of (A), and sighting through the telescope uses the horizontal fine adjustment screw to set the vertical stadia hair so that it falls down the centre of the staff. The observer then adjusts the vertical slow



Figure 13 The plane table: observing a point of detail.



Figure 14 Observing with a self-reducing alidade: adjusting the vertical screw to bring the 'zero line' to zero.

motion control (Fig 14) to place the lower horizontal stadia hair ('Zero line') to zero on the staff and reads off the graduations where the upper horizontal stadia hair ('Distance line') cuts the staff, eg if it reads 53.7cm (the .7 must be estimated by eye) then the

staff is 53.7m from the alidade (Fig 15) where the scale factor is 100. In practice the bottom of the staff is often obscured, by vegetation for instance; in this case the lower stadia hair can be placed on another convenient point, such as 1.00m, and read up from there.

Among trees much of the staff might be obscured. In this case read down from the top of the staff or from a convenient decimetre point; as long as the staff is visible where the two stadia hairs fall it does not matter if the rest is invisible. The reading should always be checked carefully under such circumstances.

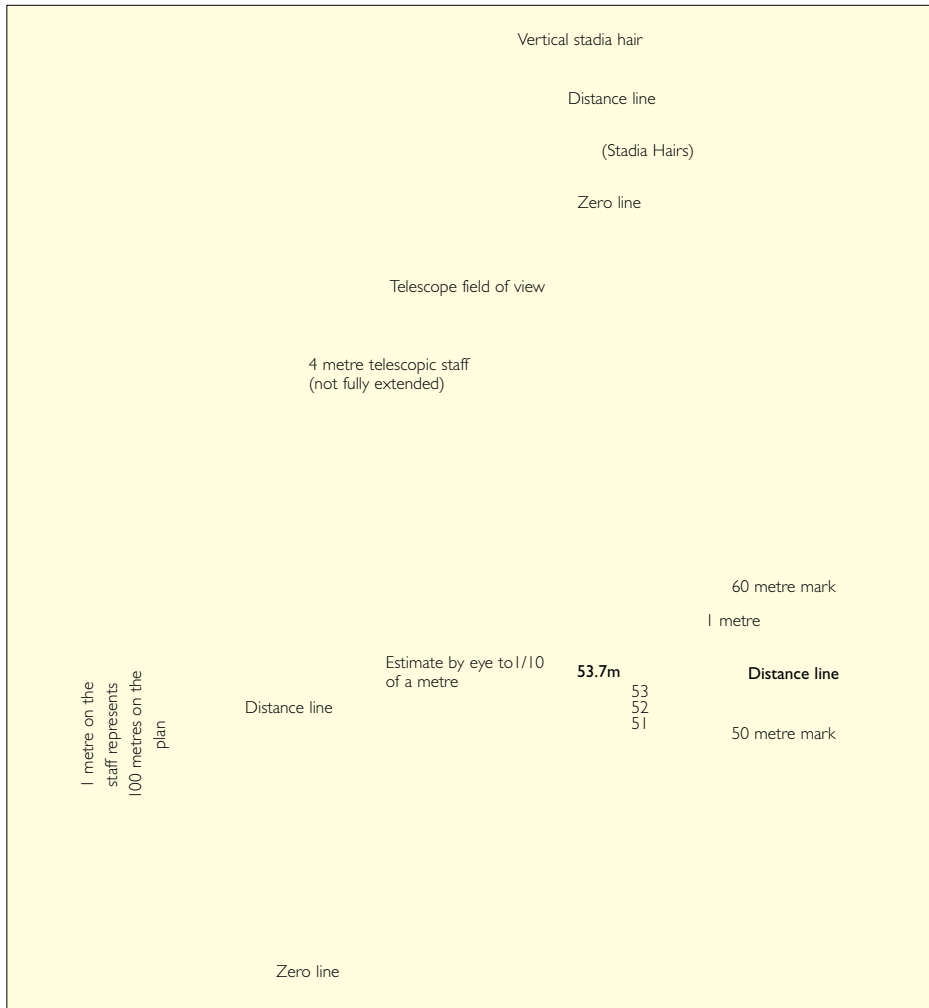

Figure 15 Distance reading with a self-reducing alidade: schematic diagram.



Figure 16 Pricking a point with a self-reducing alidade. Note that the observer has physically moved around the table to face the scale bar 'head on' and to avoid the danger of nudging the alidade by leaning across it.

Having taken the reading, being careful not to move the body of the alidade, the observer swings the parallel bar across to (A) and slides the scale bar along until the reading is 53.7 and, holding the bar steady, depresses the pricker (Fig 16). The pricked point represents the relative position of the staff to the set up, and hence the detail (E) on the plan. When ready the observer waves off the surveyor who moves to the next point, or gives subsidiary measurements from this one in the way described above, using the staff or a tape, and calling out the measurements clearly for the observer to plot. The role of the surveyor is not only interpreting the archaeology but also trying to make plotting economical for the observer.

A combination of clear spoken instructions and hand signals is essential. Consistency of instruction is also vital in the use of expressions such as 'up the ray towards you', 'down the ray away from you', for instance. Two people working together over a period will develop a system of 'verbal shorthand' and of simple hand signals, speeding up the process.

Applying checks

Apply sensible checks as you go, in accordance with good survey practice. Especially important is to check periodically the orientation of the board by observing the RO. Look at the archaeological detail to ensure that it 'looks right' and is represented correctly.

If supplying a long straight fence, for instance, it is necessary only to pick up one point at either end. However, a good check would be to pick up a third point near the centre to verify the accuracy of the line. Further checks would be a waste of time. Other features, where they cross this fence, can then be supplied by raying them in without measuring distances, the cut of the pencil line on the fence providing the required point (if the fence really is straight – within scale error). Using a telescopic alidade, when the surveyor intends the ray only to be taken, the back of the staff can be deliberately presented to the observer.

Moving on to a second station

When all detail has been obtained from the first station, a final check to the RO ensures that the table has not moved. If it *has* moved, re-align the table and re-survey the last points taken, correcting the plan. Work back until you find the point where the table moved off orientation, ie where there is no observable error. If you have been applying frequent checks this will not be a long process. The plan should be briefly compared with the ground to make sure nothing has been missed.

Move to the next station, if possible one that has already been confirmed from the first station. Take the most distant point available as an RO to obtain the longest orientation. Orient the board on the RO and obtain a tri-section, as from station (A). Start plotting detail, tying in one or two points that were supplied from the previous station as a useful check on accuracy.

There are some rules particular to plane table survey that must be followed to ensure a clear and accurate plan.

- Do *not*, under any circumstances, lean on the board; employ a light touch when moving the alidade and drawing. Try to avoid kicking the tripod legs. If you suspect that you have accidentally nudged the set-up, check immediately that the board is still horizontal and correctly orientated.

- Draw lightly. Do not obscure the graphics with unnecessarily long or heavy radiation lines.
- Wipe the alidade periodically to ensure that there is no grit that might scratch the film; this is particularly important for the relatively heavy telescopic alidades, which tend to be slid across the board rather than lifted.
- When using a staff, the surveyor should take care to hold it vertical when a reading is to be taken. If this is not done the observer has to signal the fact to the surveyor. (It can be helpful to hold the staff well off the vertical and with the face averted when a reading is *not* to be taken, eg when the surveyor has stopped to contemplate the complexity of the earthworks.)
- Check the orientation of the board periodically and at the end of the set-up.

Intersection

Another method of using the plane table, intersection, can be useful for surveying inaccessible detail, such as the far side of a river bordering a site. The plane table is set up at either end of a measured base line and rays taken to significant points.

The intersections of the rays provide the plan position of these points to a reasonable degree of accuracy. (For further detail on the method of intersection with the plane table see Coles 1972, 89–92.)

Ancillary techniques

Prismatic compass

The prismatic compass offers one of the simplest means of measuring bearings (angles related to magnetic north) accurately. It is hand-held and easily used by one person (Fig 17). As well as its use for orientation, it can be used as a low-order theodolite for measuring relative angles. While still useful for small-scale mapping and sketch surveys the prismatic compass is rarely used in large-scale survey now. Nevertheless, it has been used extensively in the past by Investigators such as RAH Farrer, who described the methodology (1987; see also Brown 1987, 54); some of Farrer's compass surveys have been subsequently checked by EDM and found to be accurate.

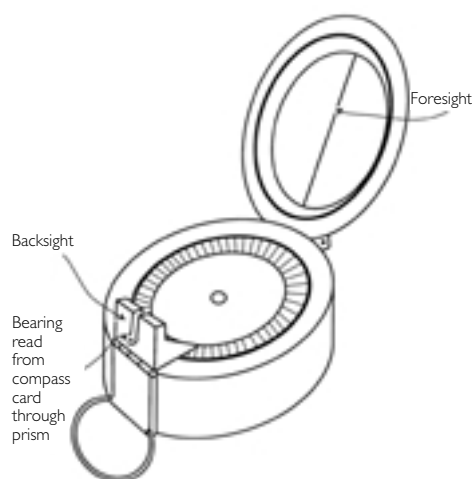

Figure 17 The prismatic compass: schematic diagram.

Two other simple instruments can be used for measuring horizontal angles. The pocket (or box) sextant was originally designed for maritime navigation in small craft but can also be used in earthwork survey.

A pantometer is a simple cross-sight revolving on a graduated horizontal circle, mounted on a small lightweight tripod, and can be used, like the prismatic compass, as a low-order theodolite.

Pocket level

In earthwork survey it is rarely necessary for tripod-mounted levelling instruments to be used. A pocket level is a hand-held instrument through which heights on a staff can be read to a level of accuracy acceptable for profiling most earthworks. It consists of a tube and a spirit level; the observer sees through the eyepiece a clear view with a horizontal cross hair on one side and the bubble of the spirit level (through a mirror) on the other – when the bubble is opposite the cross hair the instrument is level (Fig 18). The technique requires a team of two.

The pros and cons of plane tabling vis a vis tape-and-offset

These two techniques each have their own strengths and should be used appropriately.

- Tape-and-offset survey copes well with dispersed or linear features; plane tabling is more suitable for compact areas of dense detail because the 'cost' of plane tabling lies in the initial setting up of the instrument – it would not be 'cost effective' to set up a plane table where there were only a few detail points to supply within its range.
- A plane table with telescopic alidade is advantageous on broken ground or in undergrowth where it is difficult to lay out tapes.
- Plane tabling with telescopic alidade requires a team of two; tape-and-offset survey also benefits from teamwork but **can** be done by one person.
- Because a plane table is always oriented correctly with the ground angular errors, which can occur when taping-and-offsetting, are usually avoided.
- It is sometimes objected that plane tables, especially when used with telescopic

alidades, do not perform well in wind and rain; while there is some truth in this, it is nevertheless the case that they have been extensively and successfully used in the Cumbrian mountains, the Cheviots and the Yorkshire Dales for many years. On exposed sites it is wise to supply a closer network of control points so that distances observed are correspondingly shorter.

- It is also sometimes said that in plane tabling there is a tendency for one person to devote all their attention to the alidade and the plotting, whereas graphic survey places two people in direct contact with the archaeological features. In practice, however, because of the relatively short range of even telescopic alidades, the observer is always close to the detail and can (indeed should) walk over to examine the archaeological features with the investigator:

It should be clear that graphical and plane table methods can be used in combination on any site.

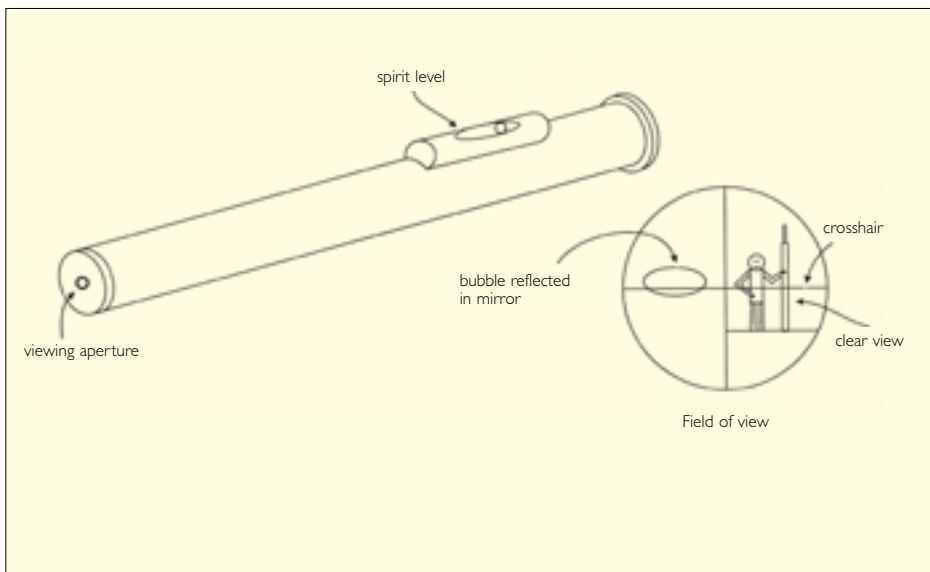

Figure 18 The pocket level: schematic diagram.

One acts as the ‘tripod’ and holds the level, adopting a comfortable stance that can be maintained without moving for some time. The other holds the staff in the same way as for a levelling exercise with a tripod-mounted instrument. The observer reads the height at the various points to be measured and, preferably, calls them to the staff holder (or a third member of the team) who books them – it is undesirable for the observer to have to move from an observing to a writing position. In the absence of a staff, a tape held vertically is a perfectly adequate substitute. Because the pocket level is not telescopic it is impossible to read heights over long distances, but this difficulty can be overcome by the staff (or tape) holder moving one finger up and down the staff (or tape) at the instruction of the observer and reading off the height.

Substantial slopes can also be measured with a pocket level if the observer’s eye-height is known. Standing at the bottom of the slope,

the observer fixes upon a distinctive stone, plant or tussock observed at eye-height through the level and walks up to it; this is repeated until the top of the slope is reached. Ideally, a colleague with a staff or tape can assist with the final observation. In this case the height of the slope is the observer’s eye-height multiplied by the number of observations taken, minus the reading on the staff at the last observation (Fig 19). In the absence of a colleague this last reading must be estimated.

Fieldworkers rapidly evolve personal rough measuring standards for recording earthwork heights – eg top of the wellington boot 0.4m, knee 0.5m, waist 1.0m, and so on. If a more accurate idea of the height of a small earthwork is necessary, a spirit level taped to a ranging rod makes a handy ‘horizontal’, which can then be laid with one end on the top of the feature and the other end against a tape measure raised vertically from the foot of the feature.



Figure 19 Measuring a substantial scarp with the pocket level: the observer’s eye height (1.6m) multiplied by the number of observations taken (3), minus the reading on the staff at the last observation (0.3m) gives the height of the scarp (4.5m)

Products

There are two principal products of an archaeological field survey – the plan and the report – but there will be various subsidiary products, such as the field notes and any profile drawings. These must be deposited in a publicly accessible archive – archiving issues are discussed in Bowden 1999 (179–86).

Field, archive and publication plans

The most immediate product of a survey is the pencil **field drawing**, showing all the control and hard detail, tops and bottoms of slopes and other detail, such as breaks of slope and vegetation changes. It will probably be annotated to a greater or lesser extent, depending on the complexity of the site and the approach of the surveyor – some like to annotate the drawing extensively rather than to use a notebook. Whether the field drawing shows the base line and other construction lines of the survey itself will also depend on the surveyors – some draw these survey lines sparingly, others erase them as they go, while others retain them. The field drawing should be marked with the site name and any appropriate reference number(s) (eg project number, or SMR/NMR/SAM number), a dated magnetic north arrow, scale information, date of survey and name(s) of the surveyor(s).

The field drawing forms the basis for the **archive drawing**. The archive drawing is a straight, accurate tracing of the field drawing, at the original survey scale, showing all detail. The top and bottom of slope lines are replaced by hachures: elongated delta-shaped symbols, which are arrayed with the heads representing the top of the slope and the tails the bottom (Figs 3 and 20). These can be drawn in such a way as to convey very subtle changes in slope (Fig 20, A–E, K–M; see also

Bowden 1999, 168–70). Hard detail will be shown (see Fig 20 for some conventions) but control points may be omitted, unless permanent markers have been left on site to aid future work – these should, of course, be shown. Various conventions have been developed to depict the most commonly encountered features (Fig 20, F–H, N–P). Any annotation should be neatly lettered, preferably by use of a stencil (stick-down lettering is not archivally stable). This should include the same information as is shown on the field drawing, but magnetic north should be replaced by grid north. The natural slope hachure (Fig 20, J), surveyed contours or estimated form lines showing the natural topography may be added.

If the survey is to be published consideration must be given to the production of a separate **publication drawing**. Publication media usually impose limitations of scale. For all but the smallest site the drawing will have to be reduced for publication, possibly entailing a change of conventions and some loss of detail. Lettering should be neat (stick-down, or computer-generated and printed on clear stick-down film, preferably) and kept to the minimum, with necessary information placed in a caption (Bowden 1999, 172–3, 188). Where profiles are used they can be added conveniently in a margin. Their positions must be shown clearly on the plan.

Field notes, archive and publication reports

The plan will mean relatively little on its own. It must be accompanied by a written report forming an extended caption, describing and interpreting the plan. **Field notes**, which form the basis for this report, could be written as survey progresses, or could be undertaken as the last stage, giving the investigator a final opportunity to look around the site, to check that nothing has been omitted and that all details have been fairly and adequately depicted. Field notes will include the heights of scarps and depths of hollows (always stating whether they are maximum or average measurements), and their forms, the all-important chronological relationships, details on the condition of the site and its interpretation, and broader observations about the topographical setting. All these elements will be valuable in writing the report. Notes of plan measurements are usually unnecessary, because they can be scaled from the plan, but where given must always state whether they are taken internally or externally, from crest to crest, from lip to lip, or whatever. Whether notes are made on the plan, in a notebook, or on a voice

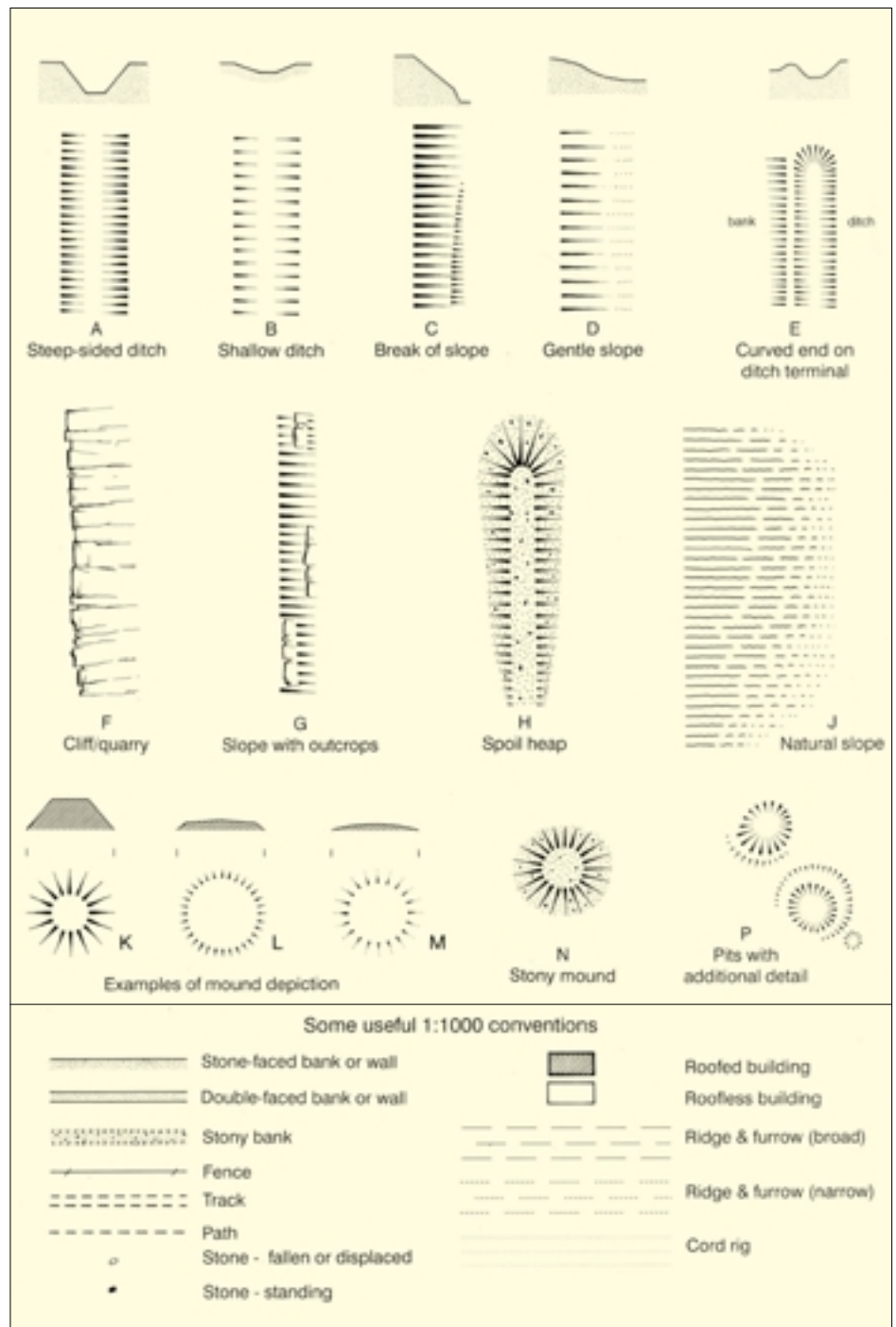

Figure 20 Drawing conventions: depictions of earthworks and associated features for archive and publication drawings.

recorder for subsequent transcription will depend upon the preferences of the individual and the requirements of the site. Descriptions, however, should always be as concise, accurate, unambiguous and comprehensive as possible.

The **archive report** will be a full descriptive and analytical account of the site. Details of the topographical location of the site, and its geology and soils, as well as a brief summary of any previous archaeological investigations should be included. All archaeological features must be described; a tabular form could be adopted for repetitive information, such as the diameters of numerous hut circles.

There must, crucially, be a discussion of the archaeological significance of the surveyed remains. The reasons for the survey and the method(s) by which it was achieved should be recorded as well as, of course, a listing of sources and bibliographical references. In some circumstances recommendations for future research, or management and conservation measures might be necessary.

Any **publication report** will omit much of the descriptive material and concentrate on the discussion, highlighting the insights gained through the recording process (Bowden 1999, 186–8).

A final word

Undertaking archaeological earthwork survey by graphical or plane table techniques is immensely rewarding. Seeing the plan grow and recognising patterns as they emerge (from even the most apparently unprepossessing set of humps and bumps) is a real thrill. Everyone makes mistakes, but with these techniques errors are instantly seen and readily corrected. There is a pleasing logic about the methodology, which, once grasped, is a source of satisfaction in its own right. Finally, spending time on a site with a plane table or some tapes, in close physical contact with the ground, gives a depth of knowledge and understanding that cannot be gained in any other way – all-but-invisible features become apparent as the site is seen from different directions and in different light conditions, and the character of the site becomes clear. Drawing the plan and writing the report to convey this understanding is an integral, and equally rewarding, part of the process.

References

Ainsworth, S, and Thomason, B forthcoming *Where in the World are We?* English Heritage

Bowden, M (ed) 1999 *Unravelling the Landscape: an inquisitive approach to archaeology*. Stroud: RCHME/Tempus

Bowden, M, Mackay, D, and Topping, P(eds) 1989 *From Cornwall to Caithness: some aspects of British field archaeology – papers presented to Norman V Quinnell*. BAR, Brit Ser 209

Brown, A 1987 *Fieldwork for Archaeologists and Local Historians*. London: Batsford

Coles, J 1972 *Field Archaeology in Britain*. London: Methuen

Ellis, P (ed) 2000 *Ludgershall Castle: excavations by Peter Addyman 1964–72*. Wiltshire Archaeol Natur Hist Soc Monogr 2 (in assoc with English Heritage)

Everson, P 2001 'Peasants, peers and graziers: the landscape of Quarrendon, Buckinghamshire, interpreted'. *Records of Buckinghamshire* 41, 1–45

Farrer, R 1987 *Survey by Prismatic Compass*. CBA Practical Handbook 2. London

Frodsham, P, Topping, P, and Cowley, D (eds) 1999. 'We were always chasing time: papers presented to Keith Blood'. *Northern Archaeol* 17/18 (special edition)

Pattison, P (ed) 1998 *There by Design: field archaeology in parks and gardens*. BAR, Brit Ser 267. RCHME/Archaeopress

Pattison, P, Field, D, and Ainsworth, S (eds) 1999 *Patterns of the Past: essays in landscape archaeology for Christopher Taylor*. Oxford: Oxbow

RCHME 1999 *Recording Archaeological Field Monuments: a descriptive specification*. Swindon: RCHME

Taylor, C 1974 *Fieldwork in Medieval Archaeology*. London: Batsford

Text by Mark Bowden. Fig 20 by Phil Newman. All other drawings by Deborah Cunliffe (Figs 6, 7, 12 and 15 based on originals by Iain Sainsbury). Photographs by James O Davies and Keith Buck.

Acknowledgements: The following commented on the text: Keith Blood, Paul Everson, Jane Golding, Amy Lax and Bernard Thomason.

English Heritage is the Government's statutory adviser on the historic environment. English Heritage provides expert advice to the Government about all matters relating to the historic environment and its conservation.

For further information (and copies of this leaflet, **quoting the Product Code**, please contact:

English Heritage
Customer Services Department
PO Box 569
Swindon
SN2 2YP

Telephone: 0870 333 1181

Fax: 01793 414926

E-mail: customers@english-heritage.org.uk

Published March 2002

Copyright © English Heritage 2002

Edited and brought to press by David M Jones,

English Heritage Publications

Designed by Simon Borrugh

Produced by English Heritage Publications

Printed by Empress Litho Ltd.

Product Code 50692



Figure 21 Plane table surveying.



ENGLISH HERITAGE